

M854™ *On-/Off-Highway*

Wide Base All-Position Radial for Severe Service Applications



Aggressive traction ■ Long wearing ■ Excellent retreadability



PRECISELY THE RIGHT TIRE.

Muscle meets mileage in the M854 all-position radial. Its advanced construction and wide base not only improve removal miles, but deliver aggressive traction in unforgiving environments—making it the ideal choice for refuse, severe service and logging applications. Plus, it's retreadable, helping maximize budgets for today's equally demanding businesses.

M854 Innovations

- A Aggressive Tread Pattern**
Provides strong traction for on-/off-highway service.
- B Stone Rejector Platforms**
Prevent trapped stones from pushing deeper into tread grooves and piercing belt layer, damaging belts and exposing them to rust.
- C 4-Rib Design**
Helps extend wear life by adding wear volume and increasing tread stiffness.
- D Multiple Gripping Edges**
Provide biting edges that help promote wet traction.

Wide Base Design

Allows for heavier loads and contributes to flotation so tires maintain grip and traction without digging into the ground.

Deep Tread

Ideal for traction in on-/off-highway environments and also leads to improved handling and long original life.

Protector Ribs

Offer resistance to cuts, snags and abrasions from curbing and impacts.

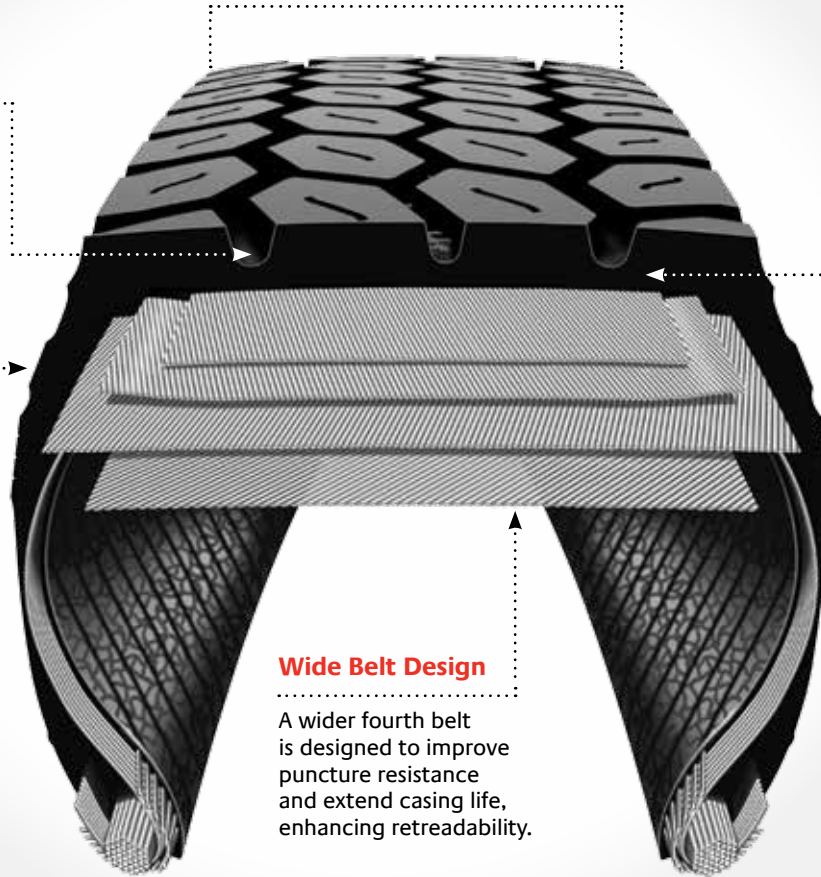

Cap/Base Compounding

Delivers longer wear life while providing resistance to cuts, chips, tears and irregular wear.

Optimized Casing Construction

Controls casing growth, providing a better footprint for longer wear life and improved irregular wear resistance, casing durability and retreadability.

Wide Belt Design

A wider fourth belt is designed to improve puncture resistance and extend casing life, enhancing retreadability.

M854 Tire Sizes	Load Range	Material Number	Weight (Lbs/kg) [†]	Meas. Rim (in.)	Overall Diameter (in./mm)	Overall Width (in./mm)	Overall Width Loaded (in./mm)	Static Loaded Radius (in./mm)	Revolutions per Mile/km	Tread Depth (32"/mm)	MAX TIRE LOAD		Max Speed (mph/kph)
											Single Lbs@PSI/kg@kPa	Dual Lbs@PSI/kg@kPa	
425/65R22.5 metric	L	233-670	189 86	12.25	44.8 1138	16.2 412	17.3 439	20.7 526	467 290	23 18	11400@120	—	65 104
											5150@830	—	
385/65R22.5 metric	J	241-439	173 76	11.75	42.9 1087	15.3 394	16.8 422	19.8 507	485 304	23 18	9370@120	—	65 104
											4250@830	—	
445/65R22.5 metric	M	241-456	217 95	13.00	45.9 1166	17.8 442	19.5 470	21.1 539	452 283	23 18	12800@130	—	65 104
											5800@900	—	

Warranty and limitation information is available at bridgestonetrucktires.com or from your Bridgestone representative, dealer or truck stop. [†]Estimated, subject to change.

Bridgestone Casings & Bandag Retreads: State-of-the-Art Smart. Pairing your Bridgestone casing with a Bandag retread extends the life of your tires and keeps your money where it belongs — with you. With specialized tread patterns that stand up to your operation's demands, plus cutting-edge compounds that resist wear and tear, Bandag retreads perform like new tires at a fraction of the cost. To get all the facts, scan the code or visit retreadinstead.com.



Prove it to yourself. Run the only test that really matters: Try the M854 on your trucks, on your routes and with your drivers — in short, in your world. See for yourself how the M854 can cut your cost per mile. Call your Bridgestone representative today!

